

CANDIDATE
NAME

--

CENTRE
NUMBER

--	--	--	--	--

CANDIDATE
NUMBER

--	--	--	--



COMBINED SCIENCE

Paper 2

5129/22

May/June 2014

2 hours 15 minutes

Candidates answer on the Question Paper.

No Additional Materials are required.

READ THESE INSTRUCTIONS FIRST

Write your Centre number, candidate number and name on all the work you hand in.

Write in dark blue or black pen.

You may use an HB pencil for any diagrams, graphs or rough working.

Do not use staples, paper clips, glue or correction fluid.

DO NOT WRITE IN ANY BARCODES.

Answer **all** questions.

Electronic calculators may be used.

You may lose marks if you do not show your working or if you do not use appropriate units.

A copy of the Periodic Table is printed on page 20.

At the end of the examination, fasten all your work securely together.

The number of marks is given in brackets [] at the end of each question or part question.

This document consists of **19** printed pages and **1** blank page.

1 Use words from the list to complete the sentences below.

osmosis **photosynthesis** **respiration**
stamens **stomata** **transpiration**
wilted **yellow**

Each word may be used once, more than once or not at all.

Water enters root hairs of a plant by the process of

Water vapour passes out of the leaves through pores called

Loss of water vapour from leaves is called

When more water is lost from leaves than is replaced by roots, a plant becomes

.....

[4]

2 Magnesium burns in carbon dioxide forming carbon and magnesium oxide.

The equation for the reaction is



(a) (i) Calculate the relative molecular mass of

carbon dioxide,

magnesium oxide.

(A_r : Mg, 24; C, 12; O, 16)

[2]

(ii) Use your answers in part (i) and the equation to complete the following sentence.

24 g of magnesium reacts with g of carbon dioxide and produces g of

magnesium oxide.

[2]

(b) Suggest why magnesium cannot be obtained from magnesium oxide by heating with carbon.

.....

.....[1]

(c) State the type of reaction that the carbon dioxide has undergone.

.....[1]

3 A circuit diagram containing two lamps **P** and **Q** is shown in Fig. 3.1.

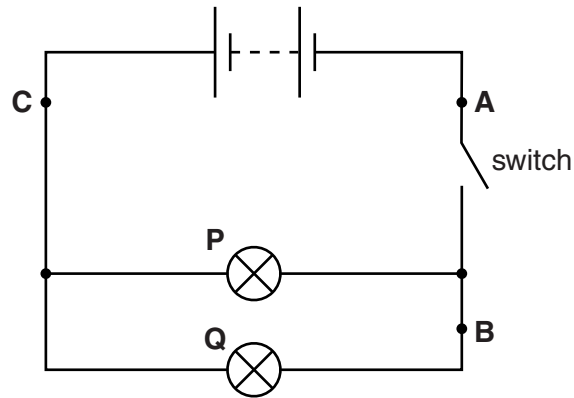

Fig. 3.1

The switch is now closed.

When the switch is closed, the current in lamp **P** is 0.3A and the potential difference across it is 6V.

(a) Calculate the resistance of lamp **P**.

resistance = unit [3]

(b) The current in lamp **Q** is 0.2A.

Determine the current in the circuit at

(i) point **A**, A

(ii) point **B**, A

(iii) point **C**, A

[3]

4 Fig. 4.1 is a photomicrograph of blood when seen through a light microscope.

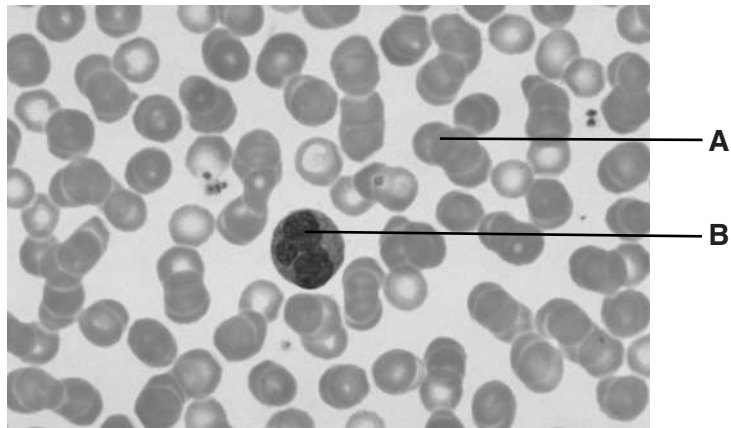

Fig. 4.1

Blood contains plasma, platelets, red blood cells and white blood cells.

(a) In Table 4.1, name components **A** and **B**.

Table 4.1

	name of blood component
A	
B	

[1]

(b) State one function for each of the following components.

platelets

.....

red blood cells

.....

white blood cells

.....

[3]

(c) Plasma transports platelets, red blood cells and white blood cells as well as other substances.

State three of these **other** substances.

1.

2.

3.

[3]

5 The electronic structure of a magnesium **atom** is shown in Fig. 5.1.

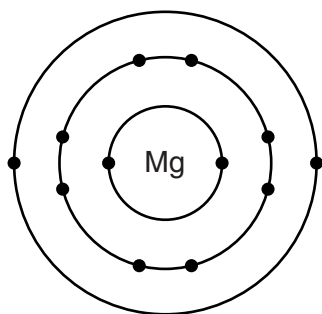

Fig. 5.1

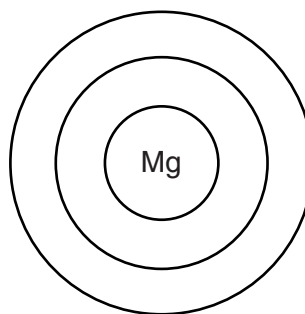

Fig. 5.2

- (a) (i) Complete Fig. 5.2 to show the electronic structure of the magnesium **ion**. [1]
 (ii) State the charge on the magnesium ion. [1]

(b) The nucleon number of an isotope of magnesium atom is 25.

Calculate the number of neutrons in a nucleus of this isotope.

.....[1]

(c) Magnesium reacts with nitric acid to produce magnesium nitrate.

(i) Complete the equation for the reaction.

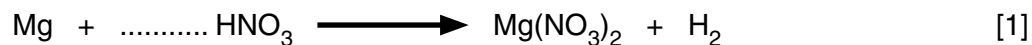

(ii) Suggest two other substances that react with nitric acid to produce magnesium nitrate.

..... and[2]

6 A boy on a diving board is shown in Fig. 6.1.

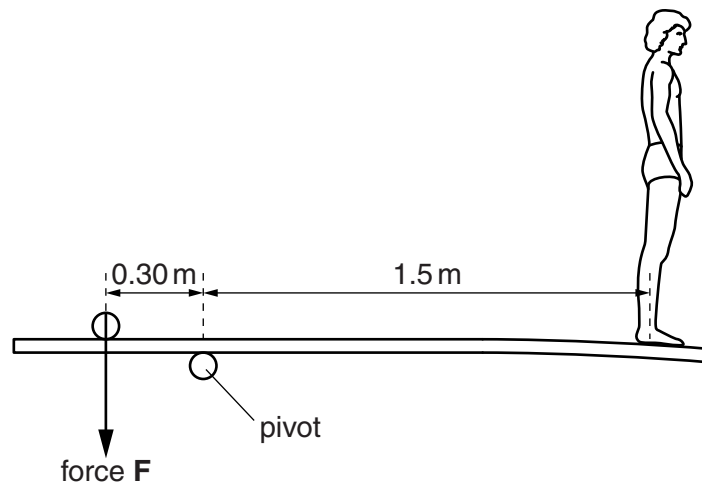

Fig. 6.1

The boy weighs 500 N and stands 1.5 m from the pivot.

The clockwise moment of the boy's weight about the pivot is equal to the anti-clockwise moment of force **F** about the pivot.

(a) Force **F** is 0.30 m from the pivot.

Calculate force **F**.

force **F** = N [2]

(b) The boy steps off the end of the diving board and falls vertically.

(i) Calculate the work done by the force of gravity on the boy as he falls through 1.2 m.

work done = unit [3]

(ii) State the type of energy lost by the boy as he falls.

..... [1]

Please turn over for Question 7

7 (a) (i) Define *diffusion*.

.....
.....
.....
.....[2]

(ii) Name two substances that diffuse across the wall of the alveolus.

- 1.
- 2.

[2]

(b) Fig. 7.1 shows a section through a group of alveoli in a lung. Part of the wall of an alveolus and the capillary next to it has been magnified.

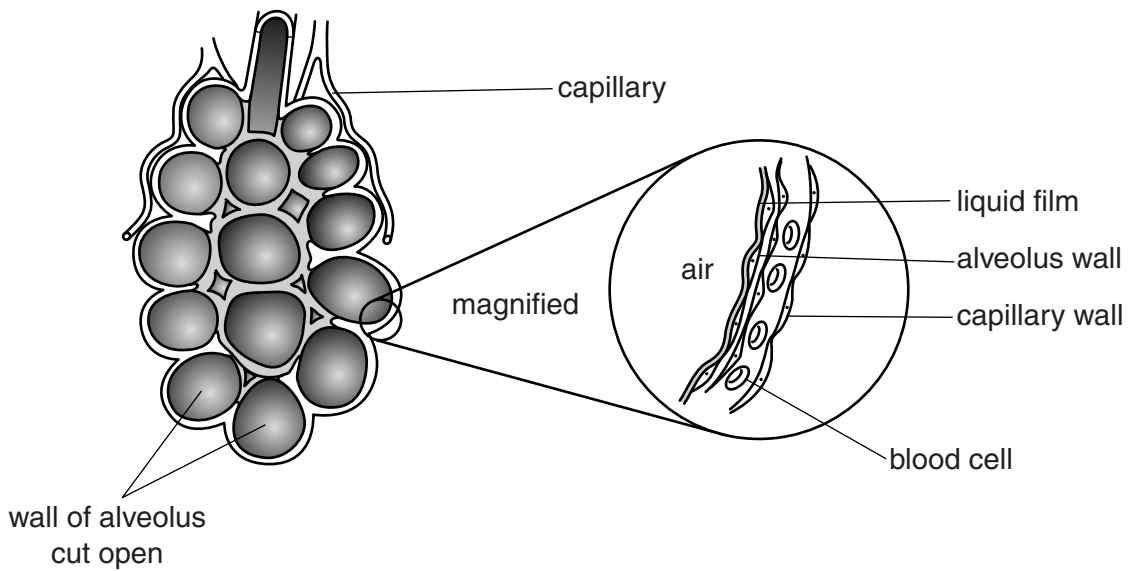

Fig. 7.1

Irritation of the cells of the alveoli produces a thicker liquid film.

(i) Suggest one cause of irritation

.....
.....[1]

- (ii) State and explain how a thicker liquid film affects the rate of diffusion across the wall of the alveolus.

.....

.....

.....

.....[2]

- (iii) Coughing helps to remove the thicker layer of liquid. Repeated coughing over many years may damage the walls of the alveoli.

Fig. 7.2 shows a group of damaged alveoli.

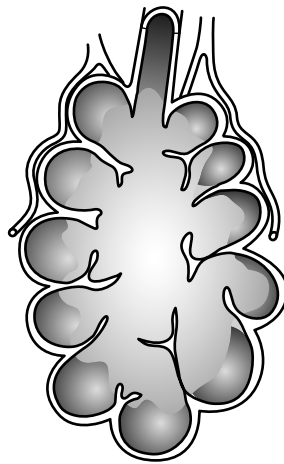

Fig. 7.2

State and explain how this damage will affect diffusion across the walls of the alveoli.

.....

.....

.....

.....[2]

8 Octane is a hydrocarbon obtained by fractional distillation of petroleum.

It is decomposed to ethene, propene and substance **X** by heating in the presence of a catalyst.

The equation for the reaction is



(a) (i) State the name of the process for the decomposition of octane.

.....[1]

(ii) Deduce the formula of **X**.[1]

(iii) Name the homologous series to which **X** belongs.[1]

(b) State what you see when aqueous bromine is added to

octane,

.....

ethene.

.....[2]

(c) Complete the diagram to show the bonds in a molecule of ethene.

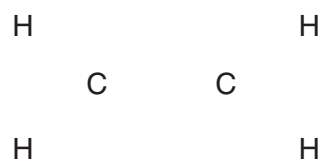

[1]

(d) State the name of the compound formed when ethene reacts with steam.

.....[1]

9 Fig. 9.1 shows a liquid-in-glass thermometer.

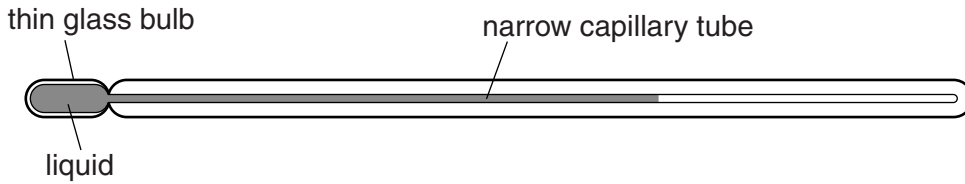

Fig. 9.1

(a) Which physical property of the liquid changes with temperature?
..... [1]

(b) The capillary tube of a clinical liquid-in-glass thermometer is narrower than the capillary tube of a normal laboratory liquid-in-glass thermometer.

Explain why a narrower capillary tube makes a clinical thermometer more sensitive.

.....
.....[1]

(c) (i) State the temperature of pure boiling water.°C [1]

(ii) Explain why a clinical thermometer is **not** used to measure the temperature of boiling water.

.....
.....[1]

10 A balloon on an insulating thread is rubbed with a duster. This removes some electrons from the balloon.

(a) State the sign of the charge now on the balloon. [1]

(b) The balloon is free to move. A second balloon with the same charge is brought near to the first balloon.

State what happens to the first balloon.

.....[1]

11 Fig. 11.1 shows a section through a flower.

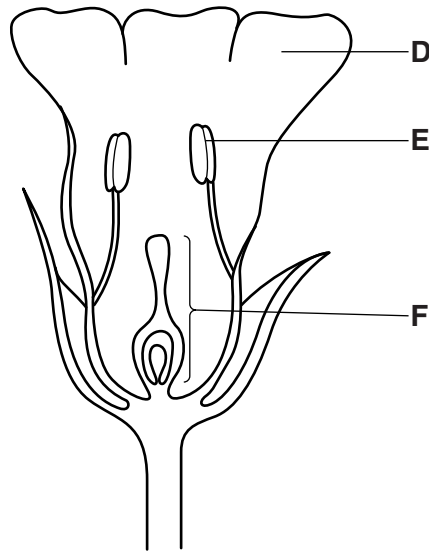

Fig. 11.1

(a) (i) In Table 11.1, name the parts of the flower **D**, **E** and **F**.

Table 11.1

	name of flower part
D	
E	
F	

[3]

(ii) State one function of the

anther,

.....

sepal.

.....

[2]

(b) Flowers produce seeds.

(i) State **two** conditions for a seed to germinate.

1.

2.

[2]

(ii) During germination, the enzyme amylase becomes active in the seed.

State and explain why amylase is necessary during germination.

.....
.....
.....
.....
.....
.....
.....

[3]

- 12 Some properties of five substances are shown in Table 12.1. The letter given for each substance is **not** the chemical symbol of that substance.

Table 12.1

substance	conducts electricity when solid	conducts electricity when melted	melting point /°C	soluble in water
V	no	no	119	no
W	no	no	-78	yes
X	no	yes	857	yes
Y	yes	yes	1083	no
Z	yes	yes	63	reacts with water

Use the letters in Table 12.1 to answer the following questions.

Each letter may be used once, more than once or not at all.

(a) The substance that is not a solid at room temperature is[1]

(b) (i) The substance that is a Group 1 metal is[1]

(ii) Give a reason for your choice in part (i).

.....
[1]

(c) (i) The substance that is an ionic compound is[1]

(ii) Give **two** reasons for your choice in part (i).

1.

 2.

[2]

13 A metal ring and a wooden rod are shown in Fig. 13.1.

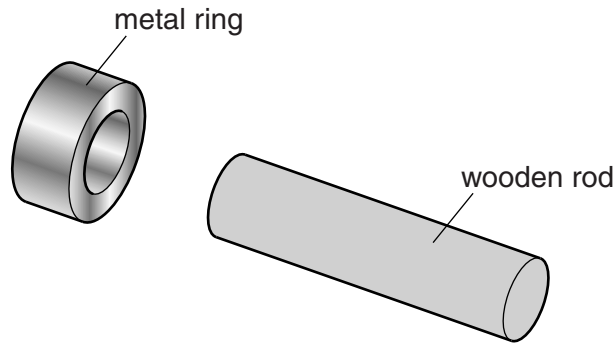

Fig. 13.1

The hole in the metal ring is too small for the wooden rod to fit inside it.

When the metal ring is heated, the wooden rod now fits inside it.

The wooden rod is pushed into the hole in the hot metal ring and the metal ring is cooled. The wooden rod cannot be removed.

(a) Explain why

(i) the wooden rod will fit inside the metal ring when the ring is heated,

.....[1]

(ii) the wooden rod cannot be removed when the metal ring cools.

.....[1]

(b) When the hot metal ring is placed on one end of the wooden rod, as shown in Fig. 13.2, the other end of the rod remains cool.

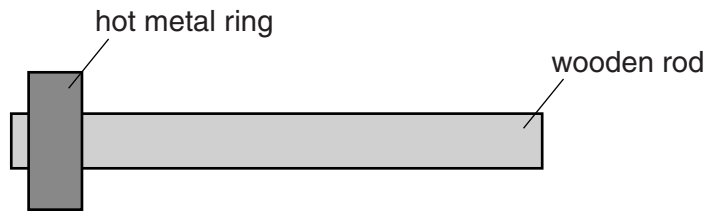

Fig. 13.2

Explain why the other end of the rod remains cool.

.....
[1]

(c) Name the method of heat transfer which

(i) involves changes in fluid density,

(ii) can transfer energy through a vacuum.[2]

14 Fig. 14.1 shows the apparatus used to pass 100 cm^3 of air over an excess of heated copper.

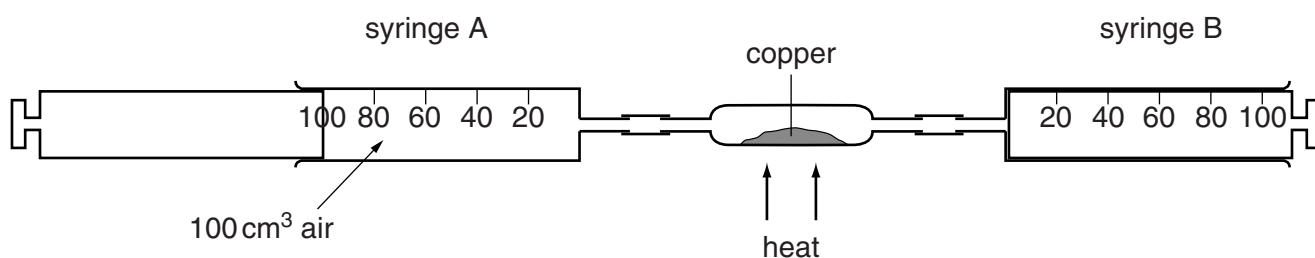

Fig. 14.1

The air is passed over the heated copper several times until there is no further change in the volume of gas. The apparatus is then left to cool to room temperature.

(a) State the name of the gas that

(i) makes up most of the air in the syringe, [1]

(ii) is removed by the copper. [1]

(b) State the final volume of gas in the syringe at the end of the experiment.

final volume cm^3 [1]

(c) (i) State the name of a pollutant produced by the combustion of fossil fuels.

..... [1]

(ii) Explain how this pollutant is produced during the combustion of fossil fuels.

.....

..... [1]

15 Some of the components of the electromagnetic spectrum are shown in Fig. 15.1.

radiowaves	A	infra-red	visible light	ultraviolet	B	gamma-rays
------------	----------	-----------	---------------	-------------	----------	------------

Fig. 15.1

(a) Name components **A** and **B**.

A

B

[2]

(b) Name

(i) the part of an atom that emits gamma-rays,

.....[1]

(ii) the surface colour that is the best absorber of infra-red radiation.

.....[1]

(c) Some light has a frequency of 4.0×10^{14} Hz and a wavelength of 5.0×10^{-7} m in glass.

Calculate the speed of this light in glass.

speed = m/s [2]

16 Many rain forests are being cut down. This causes undesirable effects on the local ecosystem.

Complete the following sentences about the destruction of the rain forests.

Cutting down trees reduces the amount of water vapour and
gas in the atmosphere and increases the amount of gas in
the atmosphere.

The number and variety of animals decrease as a result of a loss of
..... and shelter.

The loss of trees causes to be washed away more quickly.

[4]

17 Complete the following sentences about the Periodic Table.

The Periodic Table is a list of elements arranged in order of number.

The elements are on the left-hand side of the table and the elements are on the right-hand side of the table.

The vertical columns are called and the horizontal rows are called

[4]

18 A car has a mass of 800 kg.

The accelerating force on the car is 2000 N.

(a) Calculate the acceleration of the car.

acceleration =m/s² [2]

(b) The car's initial speed is zero. After some time, the constant accelerating force decreases gradually.

On Fig. 18.1 draw a line to show how the speed of the car changes with time for the constant and for the decreasing accelerating force. [1]



Fig. 18.1

BLANK PAGE

Copyright Acknowledgements:

Question 2 © Ref B06CKB; Melba Photo Agency / Alamy; *Normal Blood Cells*; www.alamy.com.

Permission to reproduce items where third-party owned material protected by copyright is included has been sought and cleared where possible. Every reasonable effort has been made by the publisher (UCLES) to trace copyright holders, but if any items requiring clearance have unwittingly been included, the publisher will be pleased to make amends at the earliest possible opportunity.

Cambridge International Examinations is part of the Cambridge Assessment Group. Cambridge Assessment is the brand name of University of Cambridge Local Examinations Syndicate (UCLES), which is itself a department of the University of Cambridge.

